

Calypso Fan-forced heater with programmable thermostat



5 year element warranty
2-year limited warranty

FEATURES

- | | |
|------------------------|---|
| Color | - White |
| Finish | - Epoxy/polyester anti-rust powder coating resistant to UV rays |
| Voltage | - 240, 60Hz, 1-phase |
| Wattage | - Regular Power (standard) 1000 W; Maximum Power (timer) 2000 W |
| Construction | - Steel cabinet featuring rounded corners and splash-proof construction for safe installation in the bathroom
- Easy-to-clean, removable rear-mounted filter for minimal maintenance
- Built-in side wire covers
- Bottom grille directs the warm air downwards, towards the centre of the room
- Two high-limit temperature controls that will turn the heater off in case of overheating, with main power interruption reset |
| Fan | - Quiet squirrel-cage fan
- Factory-lubricated motor |
| Heating Element | - Nickel-chromium alloy stitched wire, providing instant heat |
| Control | - Programmable built-in electronic proportional-action digital thermostat, located on the front panel, for regulated heating
- Electronic timer, 5-120 minutes, for accelerated heating
- LCD backlit display that can be used as a night light
- Keypad lock function using a key combination with the ability to add a code for unlocking
- Temperature display format (°C or °F)
- "On-Off" button
- "Manual" button to choose from Comfort, Economy and Frost Protection modes
- "Open Window" button to activate open window detection
- "Auto" button to enable automatic operation by following the programmed heating schedule
- Energy use indicator
- Heating indicator light |
| Installation | - Quick surface-mounted installation, with the included wall mounting bracket, that also serves as marking template
- Flexible cable with electrical wall box cover plate included
- Requires installation of a wall electrical box not supplied |
| Warranty | - 5-year heating element, 2-year parts and defects |
| Applications | - Bathroom, entrance way |

Calypso Fan-forced heater with programmable thermostat

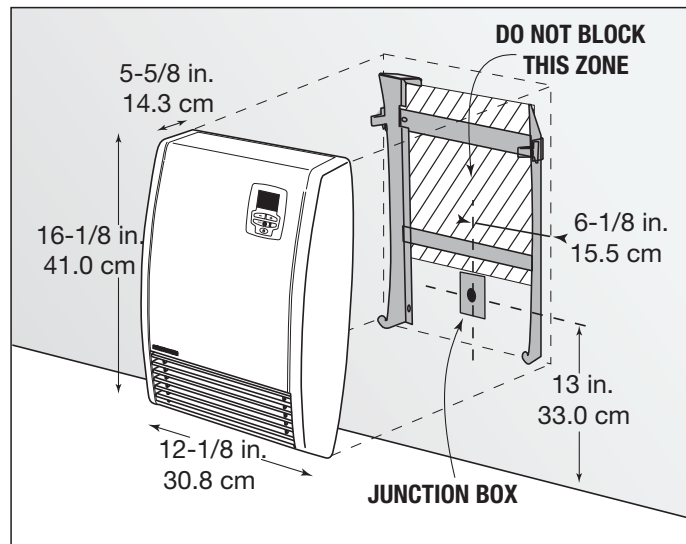

Note: The depth shown includes wall bracket.

Product No.	QTY	UPC	VOLTS	WATTS	HEIGHT		WIDTH		DEPTH		WEIGHT	
					IN	CM	IN	CM	IN	CM	LB	KG
Calypso - WHITE												
X-7826-C20-BB		781052144101	240	Regular Power (standard) 1000W Maximum Power (timer) 2000W	16-1/8	41.0	12-1/8	30.8	5-5/8	14.3	8.8	4.6

Project Details

Project:	Approval Information
Consulting Engineer:	
Electrical Contractor:	
Distributor:	
Date:	
Contact at Glen Dimplex Americas:	
Comments:	